

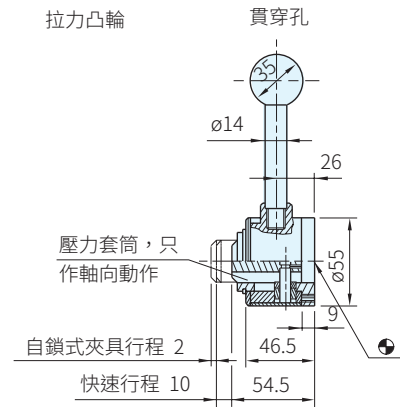

本體		把手	
材質	處理	材質	顏色
鋼	染黑	塑膠	紅

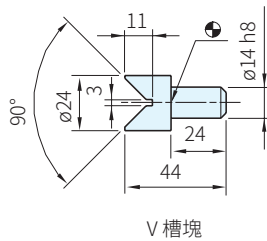
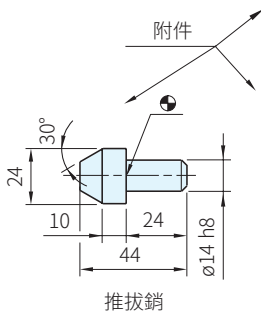
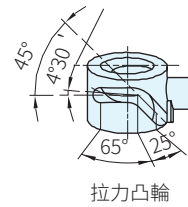
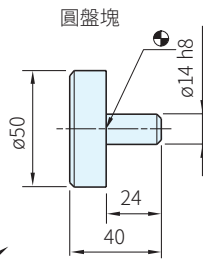
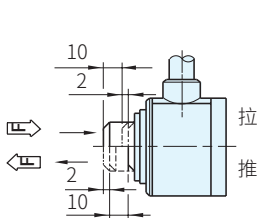
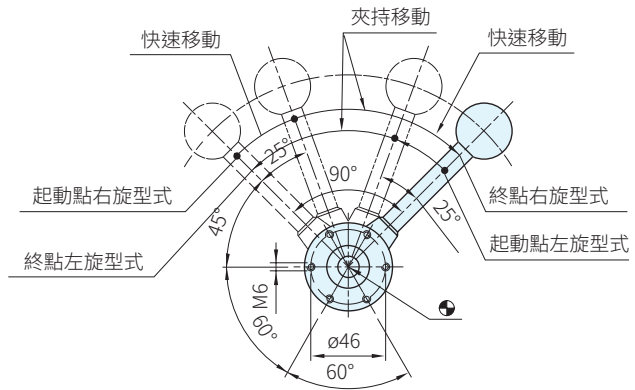
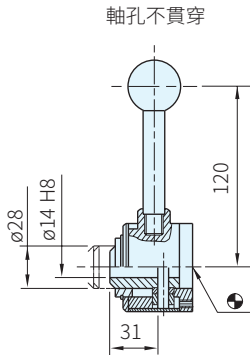

品號	備註	特性	質量 g	庫存
23260.0002	軸孔不貫穿	右推	751	△
23260.0003		右拉		△
23260.0004		左推	749	△
23260.0005		左拉		△
23260.0012	貫穿孔	右推	745	△
23260.0013		右拉		△
23260.0014		左推	750	△
23260.0015		左拉		△
23260.0042	附件	圓盤塊	270	△
23260.0044		推拔銷	85	△
23260.0046		V槽塊	82	△

**SP. 特長**

- 輕薄短小的設計，經由轉動拉力凸輪，成為推拉變化
- 移動行程是 10mm，在夾具最後 2mm 極短的移動距離內可在任何位置達到自鎖作用
- 其最大夾持力是4.9KN
- 1KN=101.792kgf

訂貨：  交期：

23260.0002

**EX. 使用例**